

FIRED BY DESIGN



OPUS



Glean from the bold and shining night  
a winter symphony  
of snow-tipped leaves, frost on the eaves  
the scent of mystery.

Put on your coat and dusty hat  
and dance into the street,  
wind in your hair, snow in the air  
and wings upon your feet.

Come to my warm and humble home,  
ensconced in peach-blue glow  
as the moon draws near, your thoughts grow clear  
like pathways in the snow.

*- E. M. Winfrey*

---

# CONTENTS

INTRODUCTION	04 - 07
CYLINDRIC	
FEATURES	10 - 15
MODELS	19 - 37
CUBIC	
FEATURES	40 - 45
MODELS	48 - 75
SCANDFIRE	76 - 77
TECH SPEC	80 - 83
ACCESSORIES	84 - 86
WARRANTY	87

---

## FIRED BY DESIGN

Fire is an elemental force, a magnet drawing us to its warm soothing light. It captivates us, soothes yet stimulates, creates space for contemplation, creation, conversation and enjoyment.

Opus stoves bring this force into your home. Designed with passionate dedication, engineered for efficiency, and built with attention; a pleasure to operate, with a focus not only on providing warmth, but also as a stage for the curling flames to weave their dance. Expansive windows allow the firelight to bathe your room in the oranges, reds, and yellows as only real flames can. The wide range of models allows you to choose exactly the look and size of stove that meets your individual requirements.

Opus stoves are available through a selected network of suppliers who are there to guide, support and advise you from the initial planning right through to the completed installation.



---

## ABOUT OPUS

Talented European designers and engineers create the overall sharp, clean and modern look which characterises Opus.

The team constantly work on developing innovations that make a stove which is a pleasure to use, beautiful to look at and supremely efficient. Independent European laboratories provide the figures which we publish for performance data such as efficiency and heat output.

Factory automation makes processes like metal cutting, rolling, and die cutting, safe and pinpoint accurate. Computer-aided systems help keep wastage to a minimum. ISO 9001 certified quality control helps to ensure that the stove reaches your living room as perfectly as intended.





---

## ECODESIGN READY

Ecodesign is an EU-wide policy set to come into force for wood stoves in 2022.

Opus stoves already meet (and beat) the tough new criteria.

Ecodesign is a set of ambitious targets designed to make the wood stoves of 2022 burn cleaner, more efficiently and to further reduce emissions.

That is an aim which we share and our tests suggest that all our stoves are Ecodesign Ready ahead of schedule.



---

## BREADTH OF CHOICE

A broad selection of models ensures that there will be something to suit every need and taste.

Opus Cylindric are rounded and upright stoves with curved glass to match. For those that favour straight edges Opus Cubic are stunning cuboid models with generous windows.

Choices and options within each range then allow you to pick your perfect stove.



---

# OPUS CYLINDRIC

Drawing inspiration from the long tradition of Scandinavian style upright woodburners.

This style of tall round woodburner looks great, featuring a raised firechamber with high generous windows. But that is not the reason they originally appeared: the Scandinavians had also discovered something else. By increasing the height of the fire chamber they were able to radically improve the combustion. When wood burns it gives off gases, and it is these which you see burning. By stretching the stove upwards more time is gained in which to properly mix the gases with enough oxygen so that they can fully burn, creating the fabulous flame pattern so characteristic of Opus stoves.

Opus Cylindric are a range of contemporary models which epitomise this design style. Their classic simplicity draws on a design heritage stretching back over 100 years.

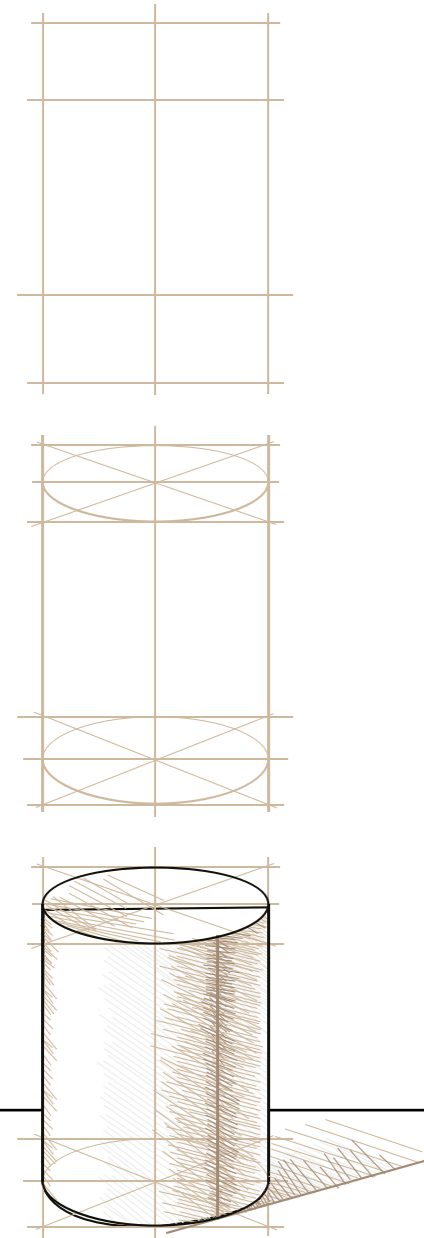

---

## LOG STORE

Instead of a door at the bottom of the stove, log store models have an open space where you can stack logs.

Look for the letter code "LS" in the product name.



---

## FULL GLASS DOOR

Models with full glass have a window which extends right to the edge of the door, creating a clean contemporary look.

Look for the letter code "G" in the product name.



---

## PEDESTAL

The central pedestal enhances the feeling of space and lightness. This model can also rotate by 90° for a perfect view of the flames wherever you sit.

Look for the letter code "PR" in the product name.



# FEATURES

Advances and innovations that make an Opus a pleasure to live with.

## CONVECTION: FOR AN EVEN HEAT

An Opus stove has two outer layers with an air gap between them. Cool air is drawn up from the floor, heated by the body of the stove, and then released out through holes at the top. This makes for a more even spread of heat in the room and keeps the body of the stove a little cooler.

## MULTI-POINT DOOR CLOSURE

Our cylindrical models all have a 2 or 3 point door mechanism, giving a positive feel and a firm closure.

## DIRECT AIR: NO MORE DRAUGHTS

All Opus stoves can be connected to an external air duct. The air needed for combustion is taken from outside the house, not from the room. This reduces draughts in your home, helping to preserve valuable cosy heat.

## THE ART OF COMBUSTION

Wood needs high temperatures and a precise supply of oxygen to burn. Opus stoves are designed to optimise the burning conditions in the fire chamber.

**PRIMARY AIR:** supplied from below the burning wood and used as a 'boost' for starting the fire, or when you have added fresh logs.

**SECONDARY AIR:** this preheated air flows down the inside surface of the window, feeding the fire and keeping the glass clean. Once the stove is hot you control the burn rate by adjusting this secondary air.

**TERTIARY AIR:** preheated air enters higher up at the back of the fire chamber through a series of holes. Look here for dancing, floating flames as the gases given off by the wood combust.

## INTUITIVE AND SIMPLE CONTROLS

Two easy to use levers give you full control of the burn rate of your stove.

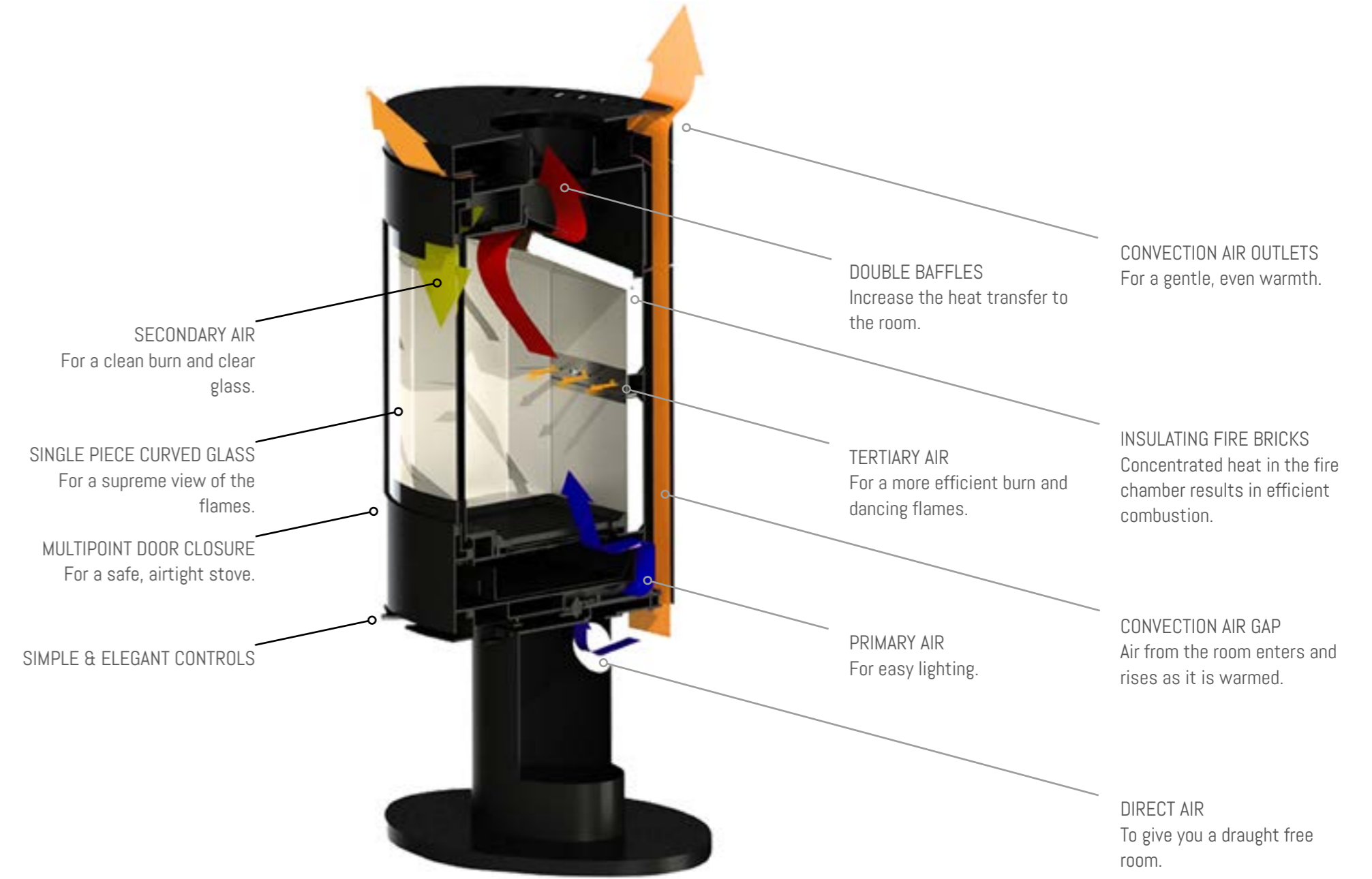

## LOW EMISSIONS

We continually innovate to improve our stoves, making them burn cleaner as well as being easier to use.

Our stoves are highly efficient and clean burning, reflected in the fact that SE models have passed the necessary lab tests and may be used to burn wood in Smoke Control Areas. Not only do our SE stoves meet

the strict emissions limits, they are between 60 and 80% cleaner than the standard requires.

SE models are indicated by a green tick.

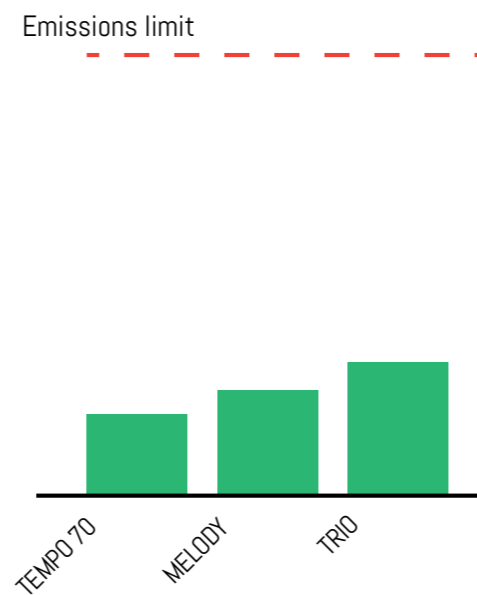

FOR YOUR OPUS STOVE TO WORK AT ITS BEST  
WELL SEASONED FIREWOOD IS VITAL  
DON'T BURN WATER



## DRY FIREWOOD

Wood is renewable, sustainable and low carbon. For your Opus to work well it must be dry or 'seasoned'.

Dry, well seasoned firewood is easier to light and burns better, it gives out much more heat, creates much less smoke, makes less tar in the stove and chimney and crucially results in lower emissions.

Burning good wood is better for your stove, better for the environment and easier on your pocket.

### HOW CAN YOU TELL?

- Look: for the "Ready to Burn" logo on wood from your firewood supplier. For more information on the scheme and a list of certified suppliers see: [www.woodsurre.co.uk](http://www.woodsurre.co.uk)
- Use: a moisture meter to test the freshly split face of a selection of logs.
- Look: for cracks across the end grain.
- Smell: wet and dry firewood have slightly differently aromas.
- Feel: wet wood is heavier. Remember that some woods are heavier than others, oak compared to ash for example.







COMPACT DESIGN  
LUXURIANT WARMTH

---

## ARIA

---

The Aria is beautiful to look at and use, a perfectly proportioned stove set off by the tall sleek handle.

Its compact height means it will fit where others cannot.

Height.....	920 mm
Width.....	472 mm
Depth.....	362 mm
Nominal output.....	5 kW
Efficiency.....	81 %
Fuel.....	Wood



A DESIGN CLASSIC  
AT HOME IN TOWN & COUNTRY

---

Height.....	1105 mm
Width.....	508 mm
Depth.....	508 mm
Nominal output .....	5 kW
Efficiency.....	77.4 %
Fuel.....	Wood
SE model available .....	✓



---

## MELODY

---

Our classic 5kW model, the Melody, is a beautiful and highly controllable woodburner. Its elegant clean lines and curved glass make this a classic piece of design.





WHEN AESTHETICS AND UTILITY MEET

Height.....	1105 mm
Width.....	508 mm
Depth.....	508 mm
Nominal output.....	5 kW
Efficiency.....	77.4 %
Fuel.....	Wood
SE model available .....	✓

### MELODY LS

The Melody LS has the same clean modern look but includes a log store for that evening's fuel.





A FULL GLASS DOOR  
A CLASSIC STOVE



MELODY GLS

Height.....	1105 mm
Width.....	508 mm
Depth.....	508 mm
Nominal output.....	5 kW
Efficiency.....	77.4 %
Fuel.....	Wood

SE model available ..... 



### MELODY G & MELODY GLS

The single curved glass window extends to the very edge of the door. This results in a gently reflective surface, framed by rich black.



## TRIO

Extra glimpses of flame entice and attract. Choose the Trio for a wonderfully wide view of the flames through three windows.

ENTICING GLIMPSES OF FLAME  
FROM 3 SIDES

Height.....	1145 mm
Width.....	505 mm
Depth.....	505 mm
Nominal output.....	5 kW
Efficiency.....	77.2 %
Fuel.....	Wood
SE model available .....	✓





HEAT AT THE TOUCH OF A BUTTON

---

Height.....	1154 mm
Width.....	505 mm
Depth.....	505 mm
Nominal output.....	3 - 5 kW
Efficiency.....	76 %
Fuel.....	Natural gas

---

---

## TRIO SCALA GAS

---

The Scala lets you light and control your stove at the touch of a button. A classic solid design, conventional or balanced flue, cosy warmth, flickering flames and a glowing ember effect.



AN OVAL SHAPE AND WIDE WINDOW GIVE  
A MAGNIFICENT DISPLAY OF FLAMES



HARMONY

Height.....	1089 mm
Width.....	598 mm
Depth.....	437 mm
Nominal output.....	7 kW
Efficiency.....	80 %
Fuel.....	Wood / Smokeless



## HARMONY & HARMONY LS

Choose a Harmony to bring warmth and life to a larger room. Easy to light, easy to use and multifuel.





FULL GLASS DOOR FOR A LUSTROUS FINISH AND TIMELESS STYLE



HARMONY GLS

Height.....	1089 mm
Width.....	598 mm
Depth.....	437 mm
Nominal output.....	7 kW
Efficiency.....	80 %
Fuel.....	Wood / Smokeless



## HARMONY G & HARMONY GLS

Perfect for warming the larger room. Classic proportions, a wide window, and the full glass door give that up-to-the-minute look.



OPEN POSSIBILITIES WITH A STOVE  
THAT YOU CAN ROTATE

---

Height.....	957 mm
Width.....	598 mm
Depth.....	437 mm
Nominal output.....	7 kW
Efficiency.....	80 %
Fuel.....	Wood / Smokeless

---

---

## HARMONY PR

---

Enhance warmth, light and space. The single pedestal leg gives the impression of lightness, adding to the room without imposing. Let the flames bring you joy and colour wherever you sit.





SHOWERS & CENTRAL HEATING  
POWERED BY YOUR OPUS

Height.....	1166 mm
Width.....	565 mm
Depth.....	462 mm
Nominal output .....	8.3 kW
room   water split.....	3.4 kW   4.9 kW
Efficiency.....	83.9 %
Fuel.....	Wood

## CALYPSO

Do it all: enjoy the cosy warmth unique to wood, make hot water for showers, and link up with your central heating system.





## OPUS CUBIC

We offer a wide range of display options and combinations. Opus Tempo stoves are being phased out, ready for the next generation to take over - so Tempo's are available while our stocks last.

Simply pick the base model according to the size or the heat output required, and then choose from the configuration options shown opposite. The base model may simply sit directly on the hearth or one can choose from a variety of presentation options: log store, pedestal, bench or wall hung. Insets, designed to be built into the wall, are available, as are double sided versions.

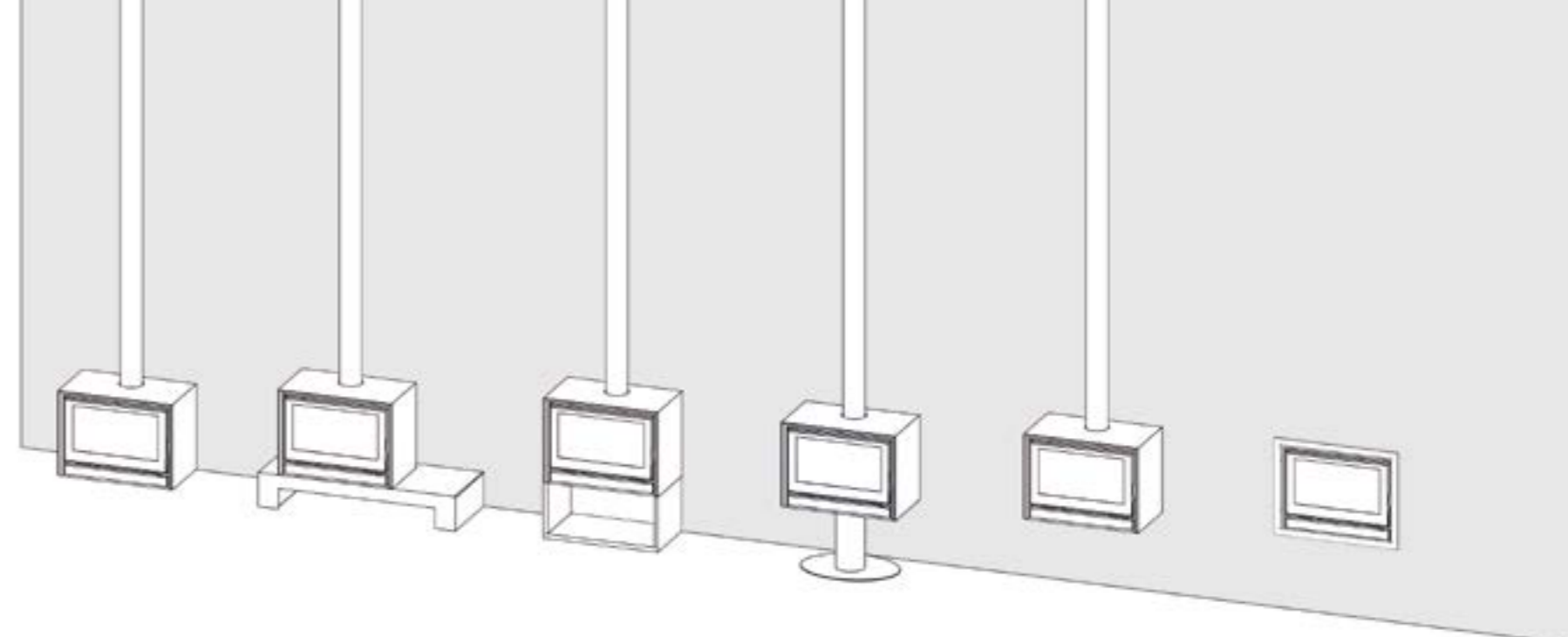

	BASE MODEL	ON BENCH	ON LOG STORE	ON PEDESTAL	WALL HUNG	INSET / BUILT-IN
TEMPO 60	✓	✓	✓	✓	✓	✓
TEMPO 70	✓	✓	✓	✓	✓	✓
DOUBLE SIDED	-	-	-	-	-	✓
TEMPO 80 DOUBLE SIDED	✓	-	-	✓	-	-
TEMPO 100 DOUBLE SIDED	✓	-	-	✓	-	-

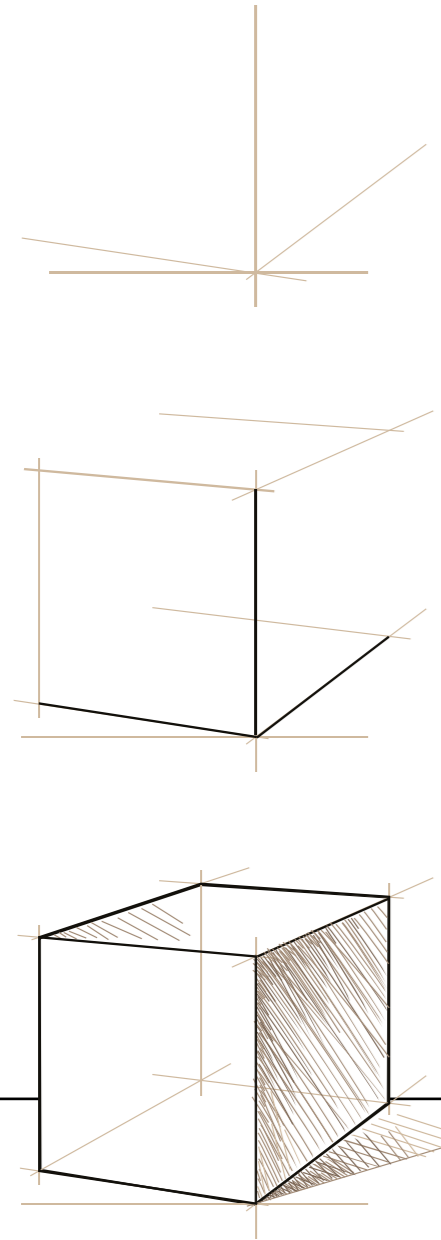



1. PREHEATED TERTIARY AIR: for efficient and complete combustion.
2. PREHEATED AIRWASH: to keep the view of the flames clear.
3. DOUBLE BAFFLES: increases efficiency and means more heat goes to the room.
4. SECONDARY AIR CONTROL: once the stove is going well this lever is used to control the burn rate.
5. PRIMARY AIR CONTROL: open this lever to provide a boost of air under the fire for lighting or refuelling. Once the stove is hot this lever would normally be in the closed position.
6. GRATE AND ASHPAN: for easy and convenient cleaning.
7. EXTERNAL AIR INTAKE: by connecting an air duct to the base or back of the stove you reduce draughts in the room, especially applicable to the modern, well sealed, home.

## LOW EMISSIONS

Opus Cubic provide optimum combustion, striking flame patterns and exacting levels of control. Pre-warmed supplies of air maintain high temperatures which promotes an efficient burn. Baffling increases the distance travelled by the hot gases which provides more heat to the room.

Advances such as these are part of the reason that the Tempo 70 SE is more than 80% below the particulate emissions threshold set for UK Smoke Control Areas.

A green tick indicates an SE model, permitted for use in Smoke Control Areas.

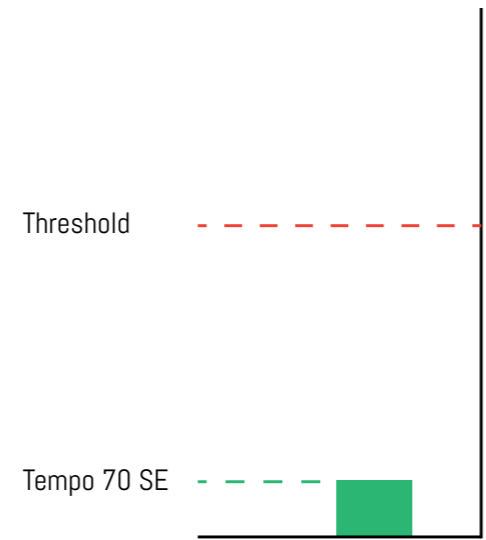

## COLLABORATION

Vision, heritage and innovation combine to bring forth Opus Cubic, the proud result of our ongoing project with Carbel to create cutting edge stoves for the homes of today.

## EXACT CONTROL

SIMPLE TO USE AND PROVIDING PRECISE CONTROL OVER THE HEAT YOU NEED



# HOW TO LIGHT YOUR STOVE

The 'upside-down' method is fast, reliable & lowers emissions even more.

For an efficient burn with low emissions you need the firebox in your stove to get really hot as quickly as possible. To burn well wood needs to be heated and any water in it driven off. Even well seasoned wood still contains a certain amount of moisture.

The upside down method is so good because it lets the kindling build up heat fast, with the larger logs only starting to catch fire once the kindling has warmed the firebox and chimney.

If you put the bigger logs on top of the kindling then they rob most of that initial heat, and so the fire takes longer to get up to temperature.

Light your Opus upside-down for quick warmth and low emissions.



Open both air controls on your stove fully, light the firelighter and close the door. If you are staying with your stove then you can leave the door ever so slightly open for the first 5 minutes as this will speed things along.

A few minutes later the kindling should be burning well. You'll see that those gaps between the kindling allow the flames to travel between the pieces of wood easily, helping the fire to spread.

Eventually the bigger logs start to catch fire and the kindling will be glowing a redder colour as it starts to turn to embers.

Once the big logs are burning strongly then you can start to adjust the burn rate by first using the primary air control, then the secondary if needed. Always aim to have good clear flames, if you see wisps of dark smoke then you may have closed the air down too much.

Eventually the larger logs will also burn to embers and then is the time to add a new log or two on top. Open up the air controls again when you add the new fuel to get it going quickly, then adjust back down once they are burning well.



Start with a couple of bigger logs and make sure there is enough room between them for the kindling stack you are about to make.



A medium sized bit of wood goes next and then the kindling. Lay them a bit like 'pick up sticks' so that they're touching, but with plenty of gaps between them.



Put a firelighter near the top and you're ready. We suggest firelighters made from wood shavings as they are renewable and a pleasure to use.







COSY WARMTH & STRAIGHT  
LINES IN DESIGN

---

Height.....	510 mm
Width.....	620 mm
Depth.....	425 mm
Nominal output.....	4.8 kW
Efficiency.....	81 %
Fuel.....	Wood

---

---

## TEMPO 60

---

The Tempo 60 may be the smallest in the range but can still kick out a decent amount of heat. A lovely controllable stove shown here with optional legs.



LINEAR SIMPLICITY  
& A BIG VIEW

---

Height.....	575 mm
Width.....	740 mm
Depth.....	420 mm
Nominal output.....	5 kW
Efficiency.....	76 %
Fuel.....	Wood
SE model available.....	✓

---



---

## TEMPO 70

---

The Tempo 70 has a large window for a 5 kW stove, giving a generous view of the flames. Site it directly on the hearth, hang it on the wall or combine it with a pedestal, log store or bench.



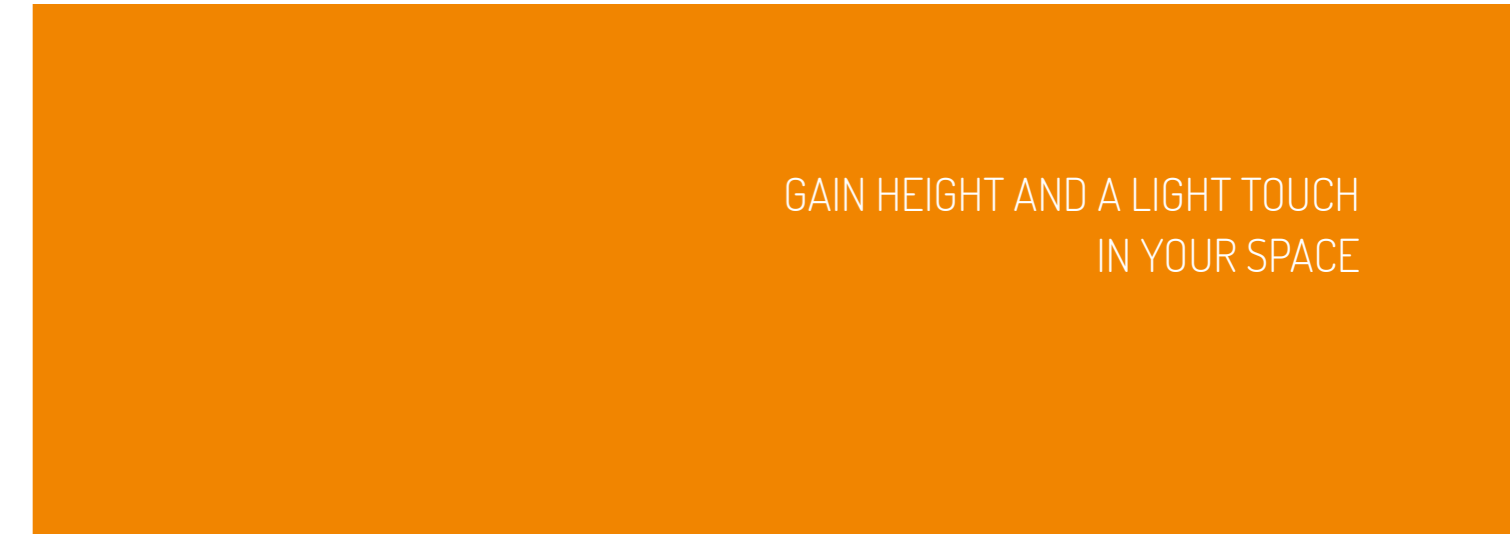

GAIN HEIGHT AND A LIGHT TOUCH  
IN YOUR SPACE

---

Height on pedestal.....	1045 mm
Width.....	740 mm
Depth.....	420 mm
Nominal output.....	5 kW
Efficiency.....	76 %
Fuel.....	Wood
SE model available .....	✓



---

## TEMPO 70 + PEDESTAL

---

Raised up 470mm on a pedestal the Tempo 70 gains height, making re-fuelling easy, and, with the flue pipe, giving the impression of a single column rising up through the stove.



LOW, ELONGATED, ELEGANT



TEMPO 70 + BENCH. BENCH DIMENSIONS H,W,D: 250MM, 1440MM, 550MM





STUNNING FLAMES ON A LOG STORE OR  
FLOATING ABOVE THE FLOOR

Height on log store.....	975 mm
Height on wall .....	up to you
Width.....	740 mm
Depth.....	420 mm
Nominal output .....	5 kW
Efficiency.....	76 %
Fuel.....	Wood
SE model available .....	✓



TEMPO 70 WALL HUNG





FREE-STANDING WITH SIMPLE LINES

Height.....	855 mm
Width.....	730 mm
Depth.....	420 mm
Nominal output.....	5 kW
Efficiency.....	76 %
Fuel.....	Wood

SE model available ..... ✓

### TEMPO 70 F

The Tempo 70 F is a free-standing stove with sides that extend smoothly down to form the legs.



## THE BUILT-IN WINDOW OF FIRE

Height on pedestal.....	1090 mm
Width.....	830 mm
Depth.....	575 mm
Output.....	14 kW
Efficiency.....	79 %
Fuel.....	Wood



### TEMPO 70i

Designed to be built into a wall or enclosure, the Tempo 70i helps to save on space in the home and provides a window of fire. The Tempo 70i is shown here with a narrow frame.



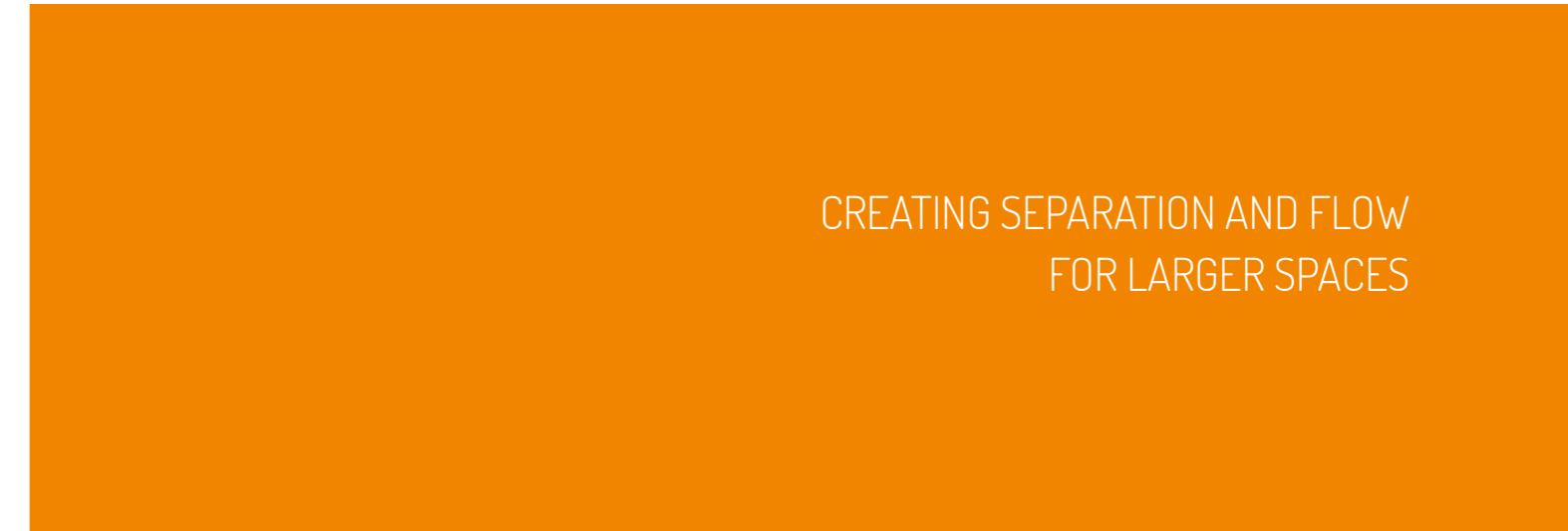

CREATING SEPARATION AND FLOW  
FOR LARGER SPACES

---

Height on pedestal.....	1090 mm
Width.....	830 mm
Depth.....	575 mm
Output.....	14 kW
Efficiency.....	79 %
Fuel.....	Wood

---

---

### TEMPO 80 DOUBLE SIDED + PEDESTAL

---

A stunning, double sided display  
of warming flames, ideal for the  
larger room.





GLIMPSES OF THE ROOM BEYOND  
INVITE

Height.....595 mm  
Width.....1005 mm  
Depth.....550 mm  
Output.....15.3 kW  
Efficiency.....79 %  
Fuel.....Wood



TEMPO 100i DS

A double sided inset stove can be enjoyed from two rooms at once. The subtle glimpse through to the other room adds dynamic space. Shown here with the narrow frame.



# OPUS SCANDFIRE

Perfect for newbuild and retrofit, this is the all-in-one solution; the stove, log store, chamber and chimney.

The Opus Scandfire system comes with everything you need to quickly and safely assemble your stove and chimney and is suitable for a timber framed or masonry construction.

Made of strong, lightweight cast pumice blocks, the chimney breast and chimney are installed during the build with the stove fitted once the plastering is finished.

The pumice is so stable and insulating that it has a zero distance to combustibles, allowing the Opus Scandfire chimney to run straight up through the fabric and insulation with no loss of air tightness.

The stove draws its combustion air down an outer duct in the chimney, removing the need for an external air duct through the wall.

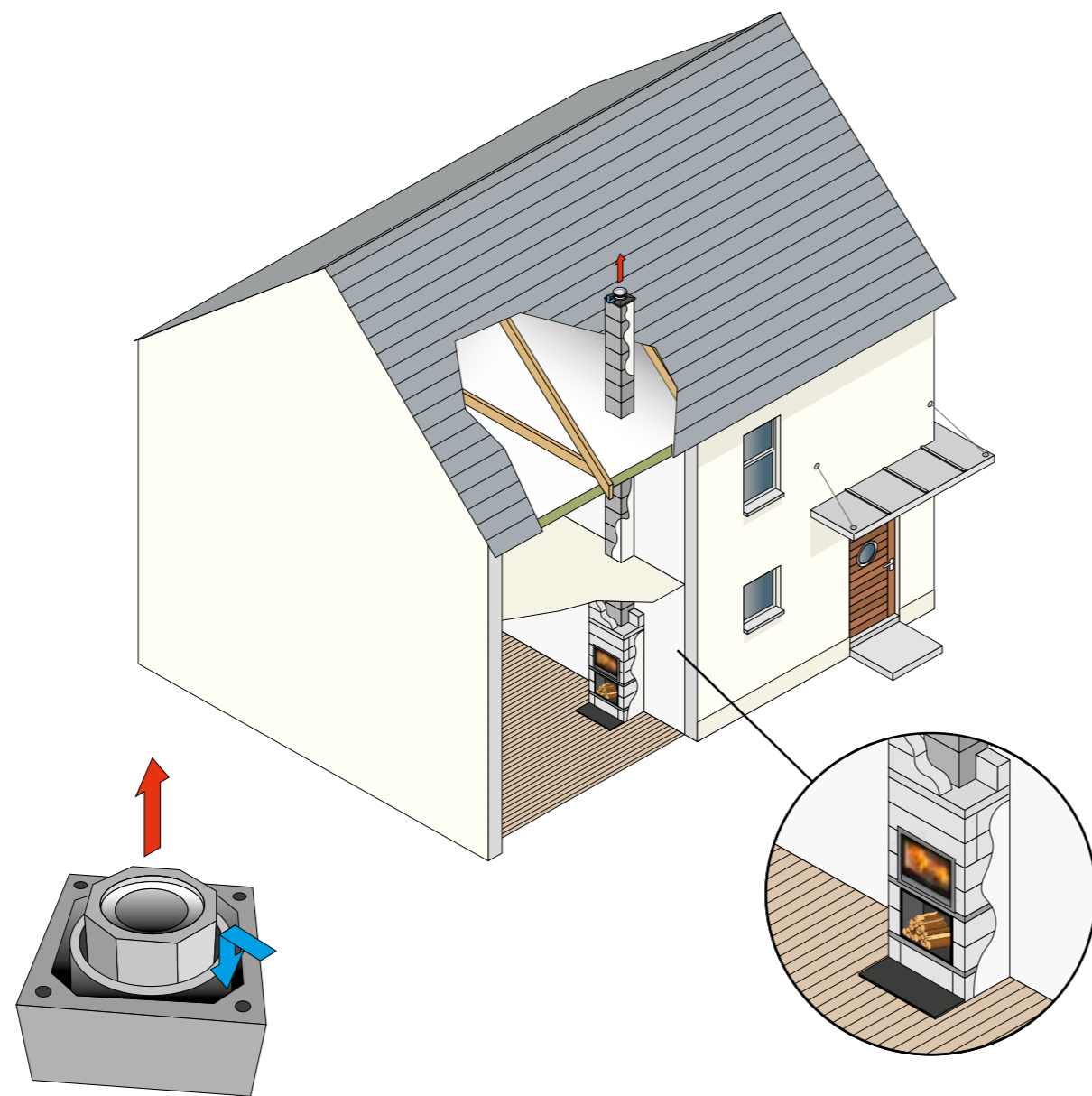



## CYLINDRIC TECH SPEC

	ARIA	MELODY, ALL MODELS	TRIO	TRIO SCALA GAS	HARMONY, ALL MODELS	HARMONY PR	CALYPSO
HEIGHT (mm)	920	1105	1145	1145	1089	957	1166
WIDTH (mm)	472	508	505	505	598	598	565
DEPTH (mm)	362	508	505	505	437	437	462
NOMINAL HEAT OUTPUT (kW) room   water split	5 -	5 -	5 -	3 - 5 -	7 -	7 -	8.3 3.4 kW   4.9 kW
EFFICIENCY (%)	81	77.4	77.2	77.2	80.0	80.0	83.9
FLUE SIZE (mm)	150	150	150	150	150	150	150
FLUE OUTLET & POSITION Back of stove to centre of top flue (mm) Floor to centre of rear flue (mm)	Top or rear 130 802.5	Top or rear 254 955	Top or rear 223 985	Top only 223 -	Top or rear 172 926	Top or rear 218 796	Top only 196 -
HEIGHT TO CENTRE OF REAR FLUE	802	955	985	985	926	946	-
SMOKE CONTROL EXEMPT MODEL AVAILABLE	-	✓	✓	✓	-	-	-
ECODESIGN READY	✓	✓	✓	-	✓	✓	✓
AIRWASH	✓	✓	✓	✓	✓	✓	✓
FUEL	Wood	Wood	Wood	Natural gas	Multifuel	Multifuel	Wood
DISTANCE TO COMBUSTIBLES REAR (mm)	250	150	120	120	200	200	100
DISTANCE TO COMBUSTIBLES SIDES (mm)	350	150	640	640	200	200	100
MAXIMUM LOG LENGTH (mm)	330	330	330	330	330	330	330

## TEMPO TECH SPEC

	TEMPO 60	TEMPO 60i	TEMPO 70	TEMPO 70 F	TEMPO 70i	TEMPO 70i DS
HEIGHT (mm)	510	495	575	855	555	555
HEIGHT ON LOG STORE	910	-	975	-	-	-
HEIGHT ON PEDESTAL	-	-	1045	-	-	-
HEIGHT ON FEET	590	-	655	-	-	-
WIDTH (mm)	622	595	740	730	695	695
DEPTH (mm)	420	425	420	420	425	550
NOMINAL HEAT OUTPUT (kW)	4.8	4.8	5	5	5	12.7
EFFICIENCY (%)	81	81	76	76	76	82
FLUE SIZE (mm)	150	150	150	150	150	200
FLUE OUTLET & POSITION Back of stove to centre of top flue (mm)	Top only 165	Top only 175	Top only 155	Top only 155	Top only 175	Top only 265
SMOKE CONTROL EXEMPT MODEL AVAILABLE	-	-	✓	✓	✓	-
ECODESIGN READY	✓	✓	✓	✓	✓	✓
AIRWASH	✓	✓	✓	✓	✓	✓
FUEL	Wood	Wood	Wood	Wood	Wood	Wood
DISTANCE TO COMBUSTIBLES REAR (mm)	500	500	200	200	200	-
DISTANCE TO COMBUSTIBLES SIDES (mm)	500	500	500	500	500	500
MAXIMUM LOG LENGTH (mm)	350	350	450	450	450	450

## TEMPO TECH SPEC

	TEMPO 80 DS	TEMPO 100 DS
HEIGHT (mm)	620	620
HEIGHT ON LOG STORE	-	-
HEIGHT ON PEDESTAL	1090	1090
HEIGHT ON FEET	700	700
WIDTH (mm)	830	1030
DEPTH (mm)	575	575
NOMINAL HEAT OUTPUT (kW)	14	15.3
EFFICIENCY (%)	79	79
FLUE SIZE (mm)	200	200
FLUE OUTLET & POSITION Back of stove to centre of top flue (mm)	Top only 287.5	Top only 287.5
SMOKE CONTROL EXEMPT MODEL AVAILABLE	-	-
ECODESIGN READY	✓	✓
AIRWASH	✓	✓
FUEL	Wood	Wood
DISTANCE TO COMBUSTIBLES REAR (mm)	-	-
DISTANCE TO COMBUSTIBLES SIDES (mm)	500	500
MAXIMUM LOG LENGTH (mm)	550	650

## OPUS SCANDFIRE TECH SPEC

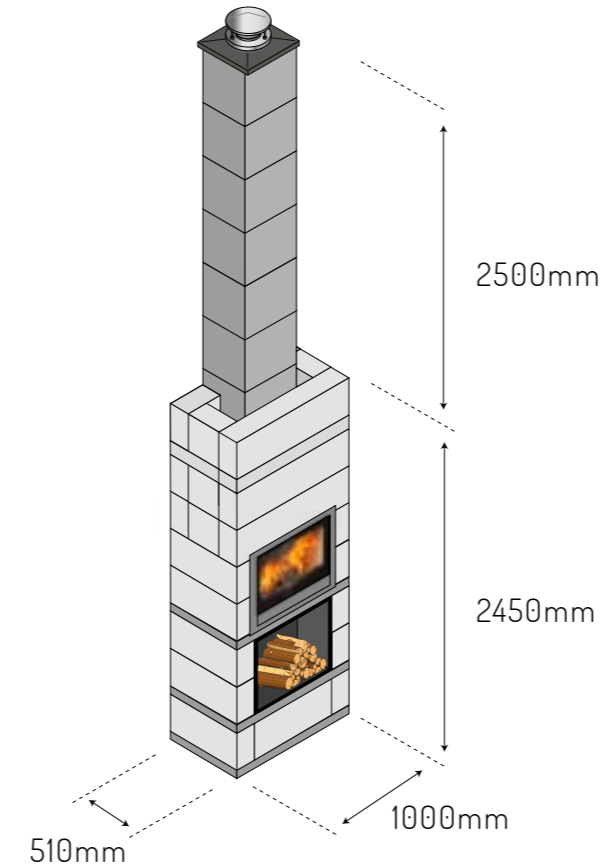

The Opus Scandfire system comes with a 2450mm high chimney breast chamber and 2500mm of chimney. Additional chimney sections are then added to the system as the project dictates. A choice of terminal is then added.

Note that only the Opus Scandfire Tempo 70 and Tempo 70 SE achieves 0mm clearance to combustibles and in this case a metal terminal must be used.

	OPUS SCAND-FIRE TEMPO 70 & TEMPO 70SE	OPUS SCAND-FIRE TEMPO 70 DS
CHIMNEY BREAST HEIGHT (mm)	2450	2450
CHIMNEY BREAST WIDTH (mm)	1000	1000
CHIMNEY BREAST DEPTH (mm)	510	510
CHIMNEY HEIGHT INCLUDED (mm)	2500	2500
ADDITIONAL CHIMNEY SECTION HEIGHT (mm)	200	200
ADDITIONAL CHIMNEY SECTION WIDTH (mm)	440	440
ADDITIONAL CHIMNEY SECTION DEPTH (mm)	440	440
INNER CHIMNEY LINER HEIGHT (mm)	250	330

---

## FRAMES

A choice of wide 90mm (see p.66), or narrow 45mm (see p.52 & p.68) frames makes it easy to neatly finish an inset stove installation.

The frame is fitted at the end of the installation, covering the expansion gap between the stove and the wall and providing a neat, clean finish.

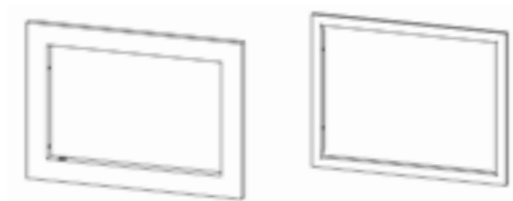

## THERMALUX

Thermalux makes installation of inset stoves fast and easy. Thermalux comes in 50mm thick sheets, is insulating and heat resistant to over 1000°C.

**EASY TO WORK WITH:** Thermalux can be worked and cut with normal woodworking tools and then glued and screwed together to quickly form walls, enclosures and pods for inset stoves, without the need for an underlying framework.

**FANTASTIC FINISH:** Primer is applied to the finished structure and it can then simply be plastered like any other wall in the home.

**QUICK:** Because it is so easy to work with, creating the structure for your installation is simple, helping you to achieve a fabulous result in a short time, wherever your imagination takes you.



---

## LOG BOX

Our log boxes provide a handy store of firewood near your stove, allowing you to incorporate the stunning natural texture of firewood into your overall design.

The two sizes of log box can be installed vertically or horizontally. A larger feature wall installation can incorporate more than one box for added impact. A dedicated kindling store can be a very useful touch.

## FRAME SPEC

Suitable for all our inset models, including double sided versions.

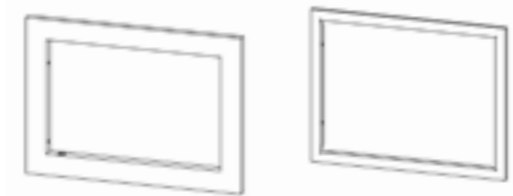

WIDE 90mm FRAME

NARROW 45mm FRAME

	WIDTH (mm)	HEIGHT (mm)	WIDTH (mm)	HEIGHT (mm)
TEMPO 70i (inc. double sided)	860	645	765	625
TEMPO 80i (inc. double sided)	950	685	855	665
TEMPO 100i (inc. double sided)	1150	685	1055	665

## BENCH

Suitable for all but the Tempo 70F, double sided, and inset models. Simple, elegant and striking.

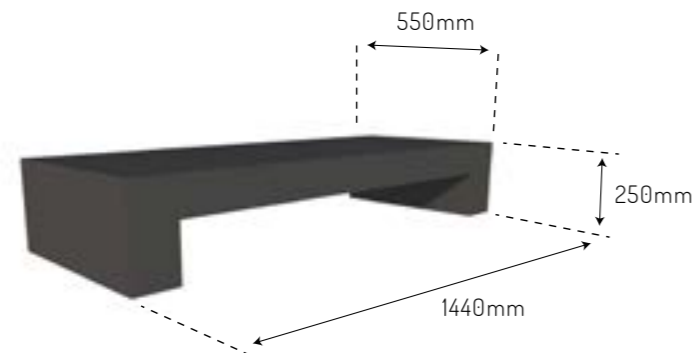

## LOG BOX SPEC

Our steel log boxes are colour-matched to Tempo stoves but are also available in matt black. A 15mm lip makes for easy and neat installation.

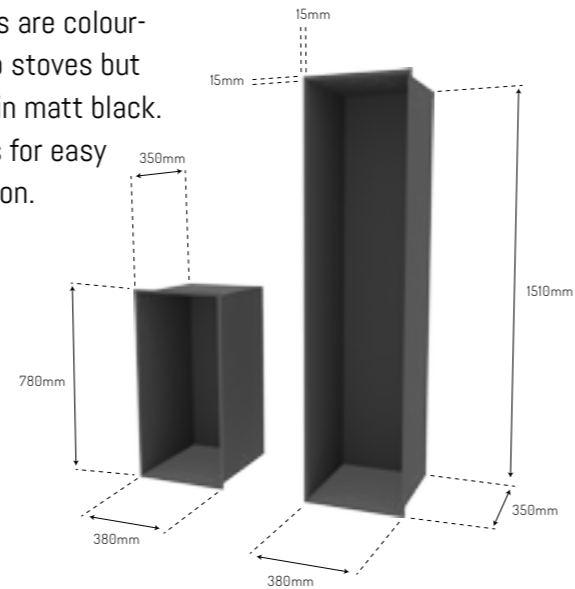

QUALITY BACKED BY  
5 YEAR WARRANTY

## WARRANTY

The reassurance of a 5 year warranty on all our stoves.

Consumables, like glass, firebricks and rope seals are excluded. Full details of the warranty can be found in the manual. Your statutory rights are not affected.





---

## LIFESTYLE, LIFECHOICE

Wood heating is one of life's simple and elemental pleasures.

Of course an Opus will do the practical work of warming your home, but much more than that it is an antidote to our busy modern world. Handling your wood gives a real understanding of its quality and the energy it represents, operating your Opus puts you in direct control of the heat. Your Opus acts as a place to gather: the flames are enticing, calming and naturally draw us in.

Being by your stove offers a chance (or welcome excuse) to reconnect with others and yourself, to ground, to rediscover, to simply be.





OPUS  
FIRED BY DESIGN

[www.opusstoves.co.uk](http://www.opusstoves.co.uk)

Opus-2019-001